

Fast Switching in Magnetic Tunnel Junctions With Two Pinned Layers: Micromagnetic Modeling

Alexander Makarov, Viktor Sverdlov, Dmitry Osintsev, and Siegfried Selberherr

Institute for Microelectronics, TU Wien, Vienna 1040, Austria

Spin transfer torque random access memory is one of the promising candidates for future universal memory. The reduction of the current density required for switching and the increase of the switching speed are the most important challenges in this area. In this paper, a penta-layer structure with two pinned magnetic layers is studied by means of extensive micromagnetic calculations. By numerically investigating the dynamics of the switching process, a methodology of how to achieve fast and symmetric switching without a compensating magnetic field is presented. Our simulations also highlight the importance of the field acting perpendicular to the plane, which facilitates switching.

Index Terms—Magnetic tunnel junction (MTJ), magnetoresistive random access memory (MRAM), micromagnetic modeling, spin transfer torque random access memory (STTRAM).

I. INTRODUCTION

WITH memories based on charge storage (such as DRAM, flash memory, and other) approaching the physical limits of scalability, research on new memory structures has significantly accelerated. Several concepts as potential substitutes of the charge memory were invented and developed. Some of the proposals are available as prototypes, such as carbon nanotube RAM (CNRAM) and copper bridge RAM (CBRAM); others already as products, e.g., phase change RAM (PCRAM), magnetoresistive RAM (MRAM), and ferroelectric RAM (FRAM); while the technologies based on spin torque transfer RAM, racetrack memory (RTRAM), and resistive RAM (RRAM) are under intensive research. A new type of memory must exhibit low operating voltages, low power consumption, high operation speed, long retention time, high endurance, simple structure, and small size [1].

The theoretical predictions [2], [3] and the experiments [4]–[8] of spin transfer switching demonstrated that the spin transfer torque random access memory (STTRAM) is one of the promising candidates for future universal memory. STTRAM is characterized by small cell size ($4F^2$), fast access time (less than 10 ns), high endurance (10^{16}), and long retention time. The basic element of the STTRAM is a magnetic tunnel junction (MTJ), a sandwich of two magnetic layers separated by a thin nonmagnetic spacer [Fig. 1(a)]. While the magnetization of the pinned layer is fixed due to the fabrication process, the magnetization direction of the free layer can be switched between the two states parallel and anti-parallel to the fixed magnetization direction. Switching between the two states occurs due to spin-polarized current flowing through the MTJ. The spin-polarized current is only a fraction of the total charge current. Therefore, high current densities are required to switch the magnetization direction of the free layer.

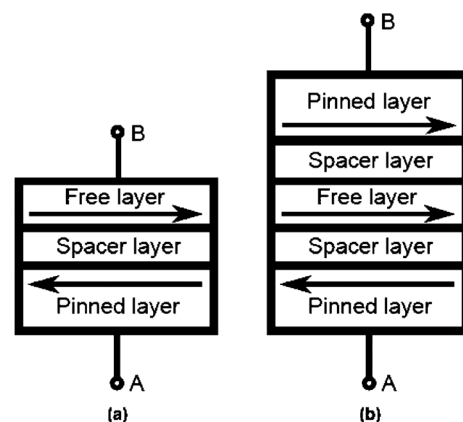

Fig. 1. Schematic illustration of (a) the three-layer MTJ and (b) the penta-layer MTJ.

The reduction of the current density required for switching and the increase of the switching speed are the most important challenges in this area. Several strategies have been proposed to decrease the switching time below a few nanoseconds: by precharging with a bias current [8], by combining a spin-polarized current together with a small radio frequency field [9], and by applying a magnetic field perpendicular to the magnetization direction [10].

Measurements [7] showed a decrease in the critical current density for a penta-layer magnetic tunnel junction with the two pinned magnetic layers in anti-parallel configuration [Fig. 1(b)] compared to the three-layer MTJ. Such a penta-layer structure was recently investigated theoretically [11] by using the ballistic Green's Function formalism combined with the soft magnetic layer dynamics based on the Landau–Lifshitz–Gilbert (LLG) equation. A spin torque enhancement was found in the anti-parallel penta-layers (the magnetizations of the two fixed layers are anti-parallel) as compared to the three-layer structure. This enhancement manifests itself only under dual barrier resonance tunneling conditions, when the current is high. At the same time, the aligned penta-layer configuration, when the magnetizations of the two fixed layers are parallel to each other, was found to have a fairly low spin torque efficiency, and as a consequence, it demands high switching currents [11]. Similar conclusions are

Manuscript received August 15, 2011; accepted October 13, 2011. Date of current version March 23, 2012. Corresponding author: A. Makarov (e-mail: Makarov@iue.tuwien.ac.at).

Color versions of one or more of the figures in this paper are available online at <http://ieeexplore.ieee.org>.

Digital Object Identifier 10.1109/TMAG.2011.2173565

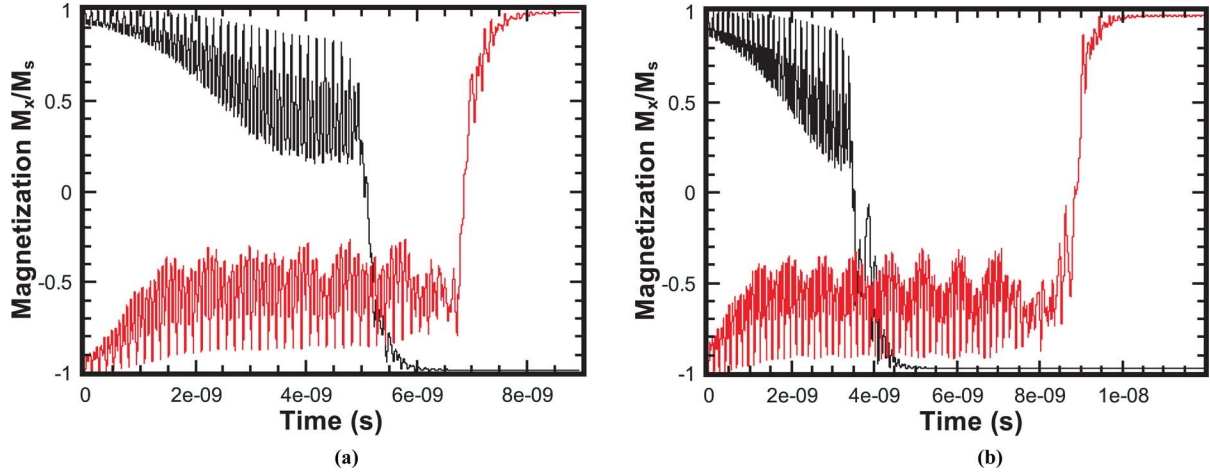

Fig. 2. Evolution of the averaged magnetization of the free ferromagnetic layer during switching in a penta-layer structure: (a) compensating magnetic field 26 mT; (b) no compensating field.

obtained under the assumptions made in [12]: It follows that in the anti-parallel configuration of the fixed layers, the spin currents from either of the pinned layers exert torques in the same direction (full torque is the sum of the individual torques), while in the parallel configurations, the torques are in opposite directions (full torque is the difference of the individual torques). The use of the model [12] is justified in structures with a free ferromagnetic layer thickness of a few nanometers. Indeed, the electron spins become aligned with magnetization at a distance approximately 1 nm away from the interface.

The spin torque enhancement in penta-layer structures results in a significantly lower critical switching current at a switching delay comparable to that in three-layer structures, which makes the penta-layer cells attractive for low-power high-performance memory applications. In this paper, by numerically investigating the dynamics of the switching process in an MTJ composed of five layers [7], we present the methodology of how to achieve symmetric switching without an external compensating magnetic field by properly engineering the nanopillar geometry.

II. MODEL DESCRIPTION

Our micromagnetic simulations are performed based on the magnetization dynamics described by the generalized LLG equation

$$\begin{aligned} \frac{dm}{dt} = & -\frac{\gamma}{1+\alpha^2} \cdot ((m \times h_{\text{eff}}) + \alpha \cdot [m \times (m \times h_{\text{eff}})] \\ & + \frac{g\mu_B j}{e\gamma M_s d} \cdot (g_1(\theta_1) \cdot (\alpha \cdot (m \times p_1) - [m \times (m \times p_1)]) \\ & - g_2(\theta_2) \cdot (\alpha \cdot (m \times p_2) - [m \times (m \times p_2)]))). \end{aligned} \quad (1)$$

Here, γ is the gyromagnetic ratio, α is the Gilbert damping parameter, g is the gyromagnetic splitting factor, μ_B is Bohr's magneton, j is the current density, e is the electron charge, d is the thickness of the free layer, $m = M/M_s$ is the position dependent normalized vector of the magnetization in the free

layer, $p_1 = M_{p1}/M_{sp1}$ and $p_2 = M_{p2}/M_{sp2}$ are the normalized magnetization of the first and second pinned layers, respectively. M_s , M_{sp1} , and M_{sp2} are the saturation magnetization of the free layer, the first pinned layer, and the second pinned layer.

We use the Slonczewski's expressions for the MTJ with a dielectrical layer [3]

$$g_1(\theta) = 0.5 \cdot \eta \cdot [1 + \eta^2 \cdot \cos(\theta)]^{-1} \quad (2)$$

and with a metal layer [2]

$$g_2(\theta) = [-4 + (1 + \eta)^3 (3 + \cos(\theta)) / 4\eta^{3/2}]^{-1} \quad (3)$$

between the ferromagnetic contacts, respectively. In the penta-layer structure, the two spin torques are acting independently on the two opposite interfaces of the free ferromagnetic layer, provided its thickness is larger than the scale on which the electron spins entering into the ferromagnet become aligned to the ferromagnet's magnetization.

The local effective field is calculated as

$$h_{\text{eff}} = h_{\text{ext}} + h_{\text{ani}} + h_{\text{exch}} + h_{\text{demag}} + h_{\text{th}} + h_{\text{amp}} + h_{\text{ms}}. \quad (4)$$

In addition to the standard external h_{ext} and the anisotropic h_{ani} micromagnetic contributions considered in [11], we also include the exchange h_{exch} and demagnetizing h_{demag} fields. h_{th} is a thermal field [13], h_{amp} is the Ampere field [14], and h_{ms} is the magnetostatic coupling between the pinned layers and the free layer.

III. RESULTS

The model geometry of the nanopillar is defined as CoFe(8 nm)/AlO_x(0.7 nm)/Py(4 nm)/Cu(6 nm)/CoFe(5 nm), with an elliptical cross section with 90- and 35-nm axes [7]. Parameters of simulation are shown in Table I.

Fig. 2(a) demonstrates an evolution of the average magnetization in the free magnetic layer during switching. A compensating external magnetic field was introduced. The results are in good agreement with those for an ideal elliptical cross section at 77 K reported in [12]. The difference between the switching

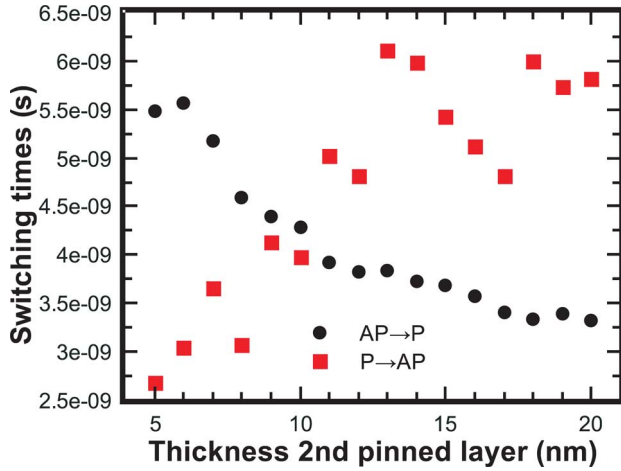

Fig. 3. Dependence of the switching times between the two stable configurations on the thickness of the second fixed magnetic layer. The thickness of the first magnetic layer is 8 nm.

TABLE I
PARAMETERS OF SIMULATIONS

Symbol	$T=77\text{K}$	$T=300\text{K}$
η_1	0.3	0.3
η_2	0.35	0.35
γ	$2.3245 \cdot 10^5 \text{m}/(\text{A} \cdot \text{s})$	$2.3245 \cdot 10^5 \text{m}/(\text{A} \cdot \text{s})$
α	0.01	0.01
A	$1.3 \cdot 10^{-11} \text{J}/\text{m}$	$1.1 \cdot 10^{-11} \text{J}/\text{m}$
M_s	$644 \cdot 10^3 \text{A}/\text{m}$	$560 \cdot 10^3 \text{A}/\text{m}$
M_{sp}	$1.15 \cdot 10^6 \text{A}/\text{m}$	$1 \cdot 10^6 \text{A}/\text{m}$

η_1 – for MTJ with dielectrical spacer

η_2 – for MTJ with metal spacer

$M_{sp1} = M_{sp2} = M_{sp}$

times from parallel to anti-parallel (with respect to the oxide tunnel junction) configuration increases when the compensating magnetic field is turned off [Fig. 2(b)]. The compensation can also be achieved by modifying the thicknesses of the fixed ferromagnetic layers and/or the distances between the layers. This opens the way to optimization of the penta-layers structure.

In the following, we investigate the influence of the thicknesses of the fixed layers on the magnetostatic field h_{ms} in the plane of the free magnetic layer. The corresponding dependence is shown in Fig. 3. Each point is a result of statistical averaging with respect to 15 different realizations of the switching process. It demonstrates that the switching time from parallel to anti-parallel configuration and vice versa depends strongly on the fixed layer thickness. The most symmetric switching is achieved when the fixed layer thickness is around 9–10 nm.

It is interesting to note that the switching time, when the compensation achieved by modifying the thicknesses of the fixed ferromagnetic layers, is shorter than in the case of an applied external field. To find the reason for this discrepancy, we stress that by varying the thickness of the fixed layer, one can only compensate the in-plane component of the magnetostatic field h_{ms} . At the same time, the field projection perpendicular to the plane is not compensated (Fig. 4). The absolute value of the average field orthogonal to the plane of the free layer is also shown in

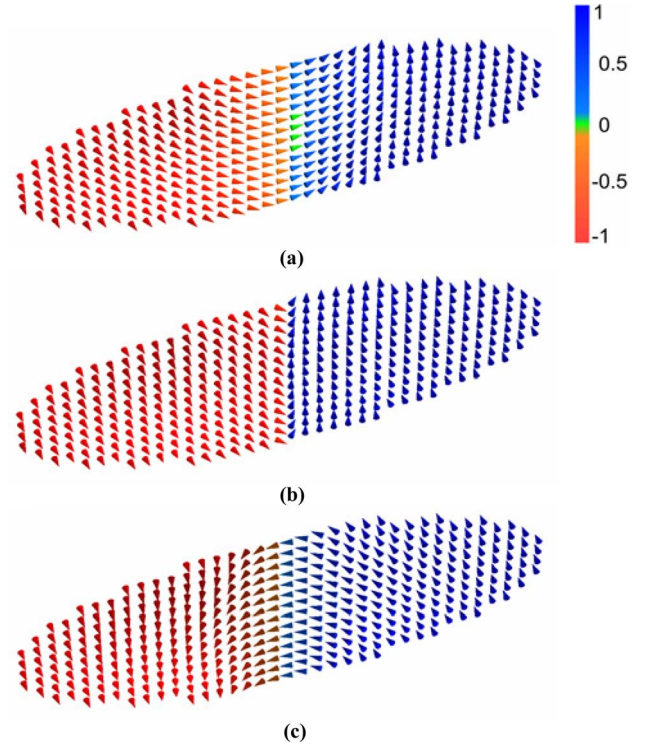

Fig. 4. Snapshots of the magnetostatic field at the plane of the free layer. Thickness of the second fixed layer is (a) 5, (b) 9, and (c) 20 nm. The direction of the magnetostatic field is shown as the unit vectors. Color indicates the out-plane component of the magnetostatic field. The in-plane component of the magnetostatic field is best compensated in panel (b). This leads to the fastest and most symmetric switching shown in Fig. 3.

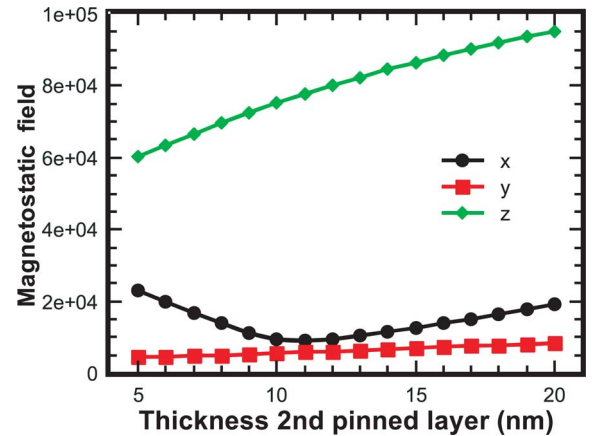

Fig. 5. Dependence of the absolute values of different components of the averaged magnetostatic field h_{ms} acting on the free magnetic layer on the thickness of the second fixed magnetic layer. The thickness of the first magnetic layer is fixed at 8 nm.

Fig. 5. This field component facilitates switching and explains the reduction in switching time.

To make the system thermally stable at room temperature, we increase the thickness of the free layer to 4.5 nm, and the elliptical cross section axes to 120 and 40 nm, correspondingly. Fig. 6 displays the dependences of the switching times as a function of the fixed layer thickness at different current densities. As the current increases, the switching time decreases, as expected. Interestingly, the dependence of the switching time on

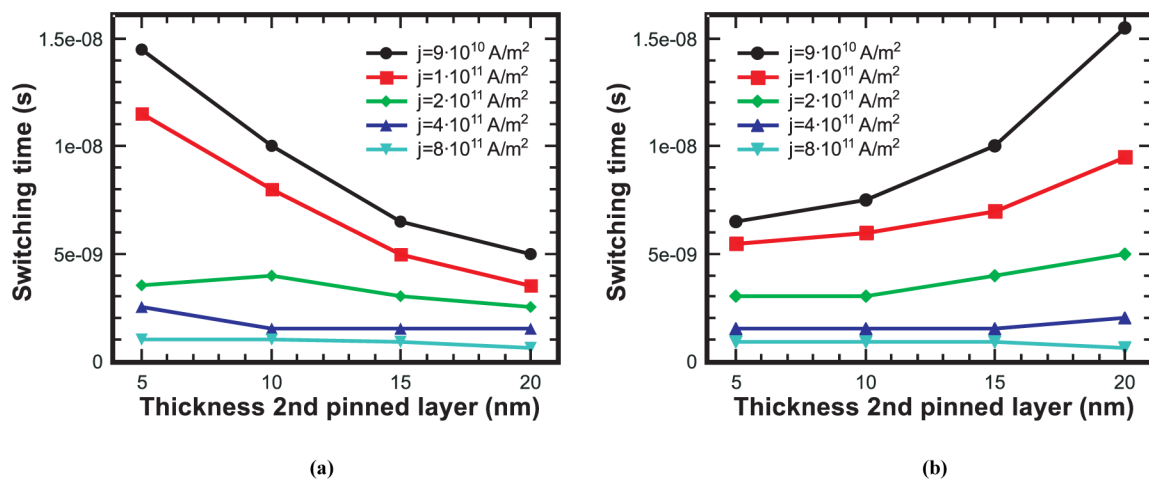

Fig. 6. Dependence of the switching time for different current densities as function of the thickness of the fixed layer. The thickness of the free layer is 4.5 nm, $T = 300$ K, and the ellipse axes are 120 and 40 nm. (a) Switching from anti-parallel to parallel configuration. (b) Switching from parallel to anti-parallel configuration.

the thickness vanishes at large current densities. This signifies that the magnetostatic coupling between the fixed and the free layers becomes irrelevant at high current densities. We stress again that, at low current densities, an optimization of a particular penta-layer structure is required to achieve the fastest and symmetric switching behavior.

IV. CONCLUSION

Magnetic tunnel junctions with two pinned layers are studied by means of extensive micromagnetic calculations. By varying the thicknesses of the fixed ferromagnetic layers and/or the separation between them, one can modulate the switching time and achieve an almost symmetric switching in asymmetric MTJs without an external magnetic field. Our simulations also highlight the importance of the field acting perpendicular to the plane. This field facilitates switching. The proposed method can be used for performance optimization of STTRAM devices.

ACKNOWLEDGMENT

This work was supported by the European Research Council under Grant #247056 MOSILSPIN.

REFERENCES

- [1] M. H. Kryder and C. S. Kim, "After hard drives—What comes next?," *IEEE Trans. Magn.*, vol. 45, no. 10, pp. 3406–3413, Oct. 2009.
- [2] J. Slonczewski, "Current-driven excitation of magnetic multilayers," *J. Magn. Magn. Mater.*, vol. 159, pp. L1–L7, 1996.
- [3] J. Slonczewski, "Currents, torques, and polarization factors in magnetic tunnel junctions," *Phys. Rev. B*, vol. 71, p. 024411, 2005.

- [4] P. M. Braganca, I. N. Krivorotov, O. Ozatay, A. G. F. Garcia, N. C. Emley, J. C. Sankey, D. C. Ralph, and R. A. Buhrman, "Reducing the critical current for short-pulse spin-transfer switching of nanomagnets," *Appl. Phys. Lett.*, vol. 87, p. 112507, 2005.
- [5] M. Iwayama, T. Kai, M. Nakayama, H. Akawa, Y. Asao, T. Kajiyama, S. Ikegawa, H. Yoda, and A. Nitayama, "Reduction of switching current distribution in spin transfer magnetic random access memories," *J. Appl. Phys.*, vol. 103, p. 07A720, 2008.
- [6] H. Meng, J. Wang, and J.-P. Wang, "Low critical current for spin transfer in magnetic tunnel junctions," *Appl. Phys. Lett.*, vol. 88, p. 082504, 2006.
- [7] G. D. Fuchs, I. N. Krivorotov, P. M. Braganca, N. C. Emley, A. G. F. Garcia, D. C. Ralph, and R. A. Buhrman, "Adjustable spin torque in magnetic tunnel junctions with two fixed layers," *Appl. Phys. Lett.*, vol. 86, p. 152509, 2005.
- [8] T. Devolder, C. Chappert, P. Crozat, A. Tulapurkar, Y. Suzuki, J. Miltat, and K. Yagami, "Precharging strategy to accelerate spin-transfer switching below the nanosecond," *Appl. Phys. Lett.*, vol. 86, p. 062505, 2005.
- [9] G. Finocchio, I. Krivorotov, M. Carpentieri, G. Consolo, B. Azzaroni, L. Torres, E. Martinez, and L. Lopez-Diaz, "Magnetization dynamics driven by the combined action of ac magnetic field and dc spin-polarized current," *J. Appl. Phys.*, vol. 99, p. 08G5007, 2006.
- [10] T. Devolder, P. Crozat, J.-V. Kim, C. Chappert, K. Ito, J. A. Katine, and M. J. Carey, "Magnetization switching by spin torque using sub-nanosecond current pulses assisted by hard axis magnetic fields," *Appl. Phys. Lett.*, vol. 88, p. 152502, 2006.
- [11] N. N. Mojumdar, C. Augustine, D. E. Nikonov, and K. Roy, "Effect of quantum confinement on spin transport and magnetization dynamics in dual barrier spin transfer torque magnetic tunnel junctions," *J. Appl. Phys.*, vol. 108, p. 104306, 2010.
- [12] G. Finocchio, B. Azzaroni, G. D. Fuchs, R. A. Buhrman, and L. Torres, "Micromagnetic modeling of magnetization switching driven by spin-polarized current in magnetic tunnel junctions," *J. Appl. Phys.*, vol. 101, p. 063914, 2007.
- [13] G. Finocchio, M. Carpentieri, B. Azzaroni, L. Torres, E. Martinez, and L. Lopez-Diaz, "Micromagnetic simulations of nanosecond magnetization reversal processes in magnetic nanopillar," *J. Appl. Phys.*, vol. 99, p. 08G522, 2006.
- [14] L. Torres, L. Lopez-Diaz, E. Martinez, and O. Alejos, "Micromagnetic dynamic computations including eddy currents," *IEEE Trans. Magn.*, vol. 39, no. 5, pp. 2498–2500, Sep. 2003.